

INSTALLATION INSTRUCTIONS		NOTES AND SAFETY INSTRUCTIONS	
<p>Hole spacing (D) stated above are depending on the actual fixture. Mounting screws not included.</p>	<p>Tc max=100°C Risk group (EN 62471:2008)=1</p> <p>Installation cable must JETport 110 °C temperature. Feeding cable must be cable pipe 3x1.5mm<sup>2</sup> and 3x2.5mm<sup>2</sup>. Installation may require advice from a qualified person.</p> <p>Fitting must only be used complete with their protection cover. Tempered protection glass of Ø153 and 5mm thickness. Avoid contact with glass: high temperatures.</p>	<p>General safety instructions: information on restrictions related to use of the light fixtures (class, IP, etc.) can be found both on the fixture label and on our website at <a href="http://www.rovasi.com">www.rovasi.com</a>.</p> <p>The wiring schematics can be found on page 2 of the document.</p> <p><b>Electronic equipment:</b></p> <p><b>S:</b> ON / OFF <b>D:</b> DALI/DSI/switchDIM/corridorFUNCTION</p> <p>* Add any of the above suffixes <b>-S, -D</b>, after the reference to indicate your electronic equipment choice.</p>	<p>11W / 350mA</p> <p>101SUP-I191 101SUP-I192 101SUP-I193</p>

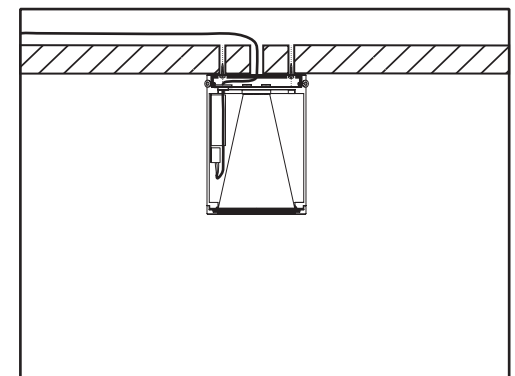
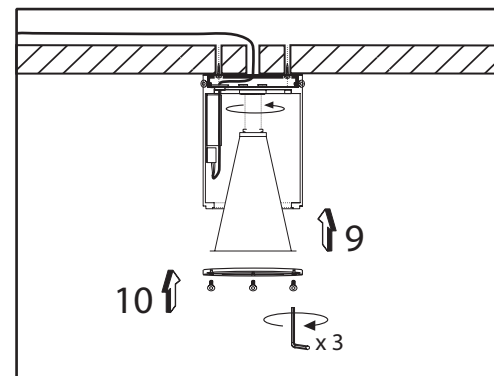
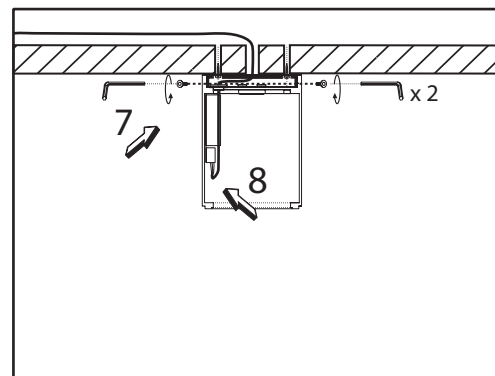
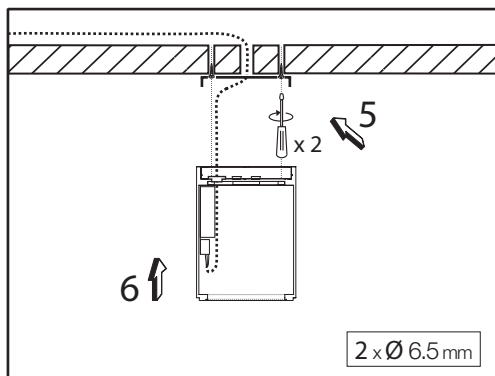

LED technology and performance data are constantly changing. Current details should therefore be checked with ROVASI in order to ensure that it is still the most up to date reference. Updated data will be supplied on request. [07.09.2016]

**Installation instructions. Mains supply wires**

- Wiring type and cross section
- Stranded wire or solid wire up to 2,5mm<sup>2</sup> may be used for wiring.
- Strip 10-11mm of insulation from the cables to ensure perfect operation of the push terminals.
- Use one wire for each terminal connector only.
- Use each strain relief channel for one cable only.
- Installation may require advice from a qualified person.

**Wiring guidelines**

- All connections must be kept as short as possible to ensure good EMI behaviour.
- Earthing is not required for the device to operate but will improve the EMI behaviour.
- Mains leads should be kept apart from LED control gear and other leads (ideally 5 – 10 cm distance)
- Secondary switching is not permitted.
- Incorrect wiring can damage LED modules.

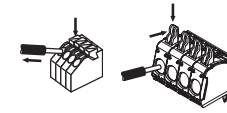

Release of the wiring  
Press down the "push button"  
and remove the cable from front.

Circuit diagram **S: Standard**

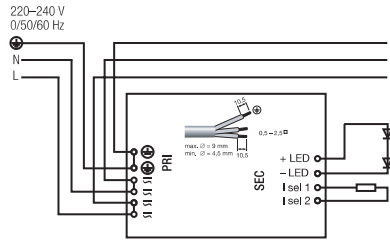

Circuit diagram **A: 1-10V<sup>⊙</sup>**

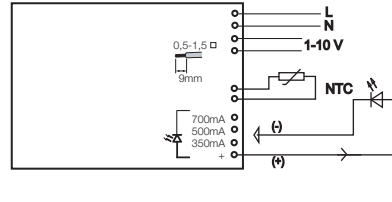

<sup>⊙</sup> Only available for following power: 11W / 17W / 23W-24W

Circuit diagram **D: DALI/DSI/SwitchDIM/corridorFUNCTION**

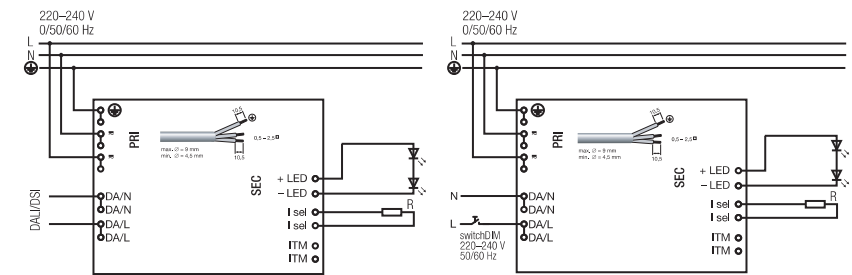

**Maximum lead length**

LED 3m<sup>⊙</sup>  
Status indication LED 1m  
Batteries 1.3m  
Insolation and electric strength testing of luminaires

<sup>⊙</sup> Note: The length of LED module must not be exceeded. Note that the length of the EM converterLED leads to the LED module will be added to the length of the leads from the control gear to the EM converterLED module when considering the lead length of the control gear. Leads should always be kept as short as possible.

**Wiring guidelines**

· The LED terminals, battery, indicator LED and test switch terminals are classified as SELV (output voltage <60V DC).

Keep the wiring of the input terminals separated from the wiring of the SELV equivalent terminals or consider special wiring (double insulation, 6mm creepage and clearance) when these connections should be kept SELV.

· The output to the LED is DC but has high frequency content, which should be considered for good EMC compliance.

· LED leads should be separated from the mains connections and wiring for good EMC performance.

· Maximum lead length on the LED terminals in 3m. For a good EMC performance keep the LED wiring as short as possible.

· Maximum lead length for the Test switch and indicator LED connection is 1m. The test switch and indicator LED wiring should be separated from the LED leads to prevent noise coupling.

· Battery leads are specified with 0.5mm cross section and a length of 1.3m.

EM: Electromagnetic  
EMC: Electromagnetic Compatibility  
DC: Direct current  
SELV: Safety extra low voltage

<sup>⊙</sup> Only available for following power: 11W / 17W / 23W-24W

Circuit diagram **SE: Emergency kit**

EM converterLED BASIC with a standard LED control gear and one LED module for mains and emergency operation

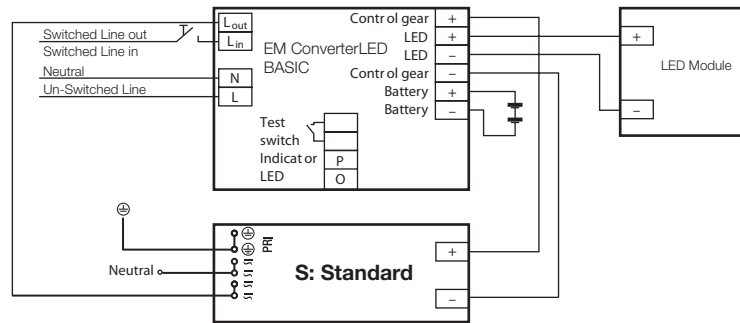

Circuit diagram **AE: 1-10V + E-kit<sup>⊙</sup>**

EM converterLED BASIC with a standard LED control gear and one LED module for mains and emergency operation

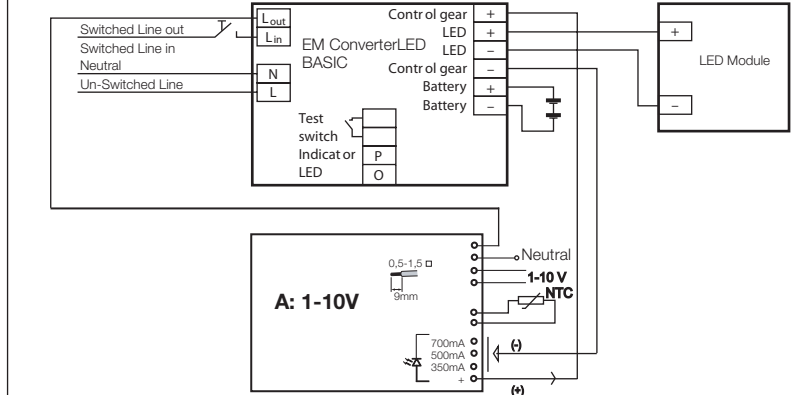

Circuit diagram **DE: DALI/DSI/SwitchDIM/corridorFUNCTION + E-kit**

EM converterLED BASIC with a standard LED control gear and one LED module for mains and emergency operation

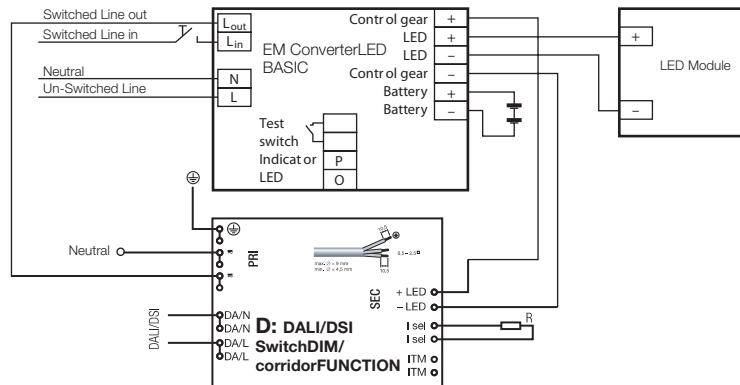

Circuit diagram **DE: DALI/DSI/SwitchDIM/corridorFUNCTION + E-kit**

